



 hauraton

DRIVETEC

Linear channel suitable for
driveways, residential areas
and public spaces

DRIVETEC

DRIVETEC is a domestic lightweight channel suitable for lightly trafficked areas such as public spaces and residential properties.



Superior performance

Drainage cross-section of 95cm² offers best-in-class hydraulic performance.



Virtually unbreakable

Our composite channel bodies are made with robust material that will withstand impact damage during transport and movement on site.



Safe to lift

DRIVETEC starts at only 3.26kg per metre making it both easy to manoeuvre and install.



Features of DRIVETEC

Grating options

- Available in standard composite, heel-safe composite or heel-safe ductile iron

Increased stability

- Centre bolts help secure the grating firmly to the channel

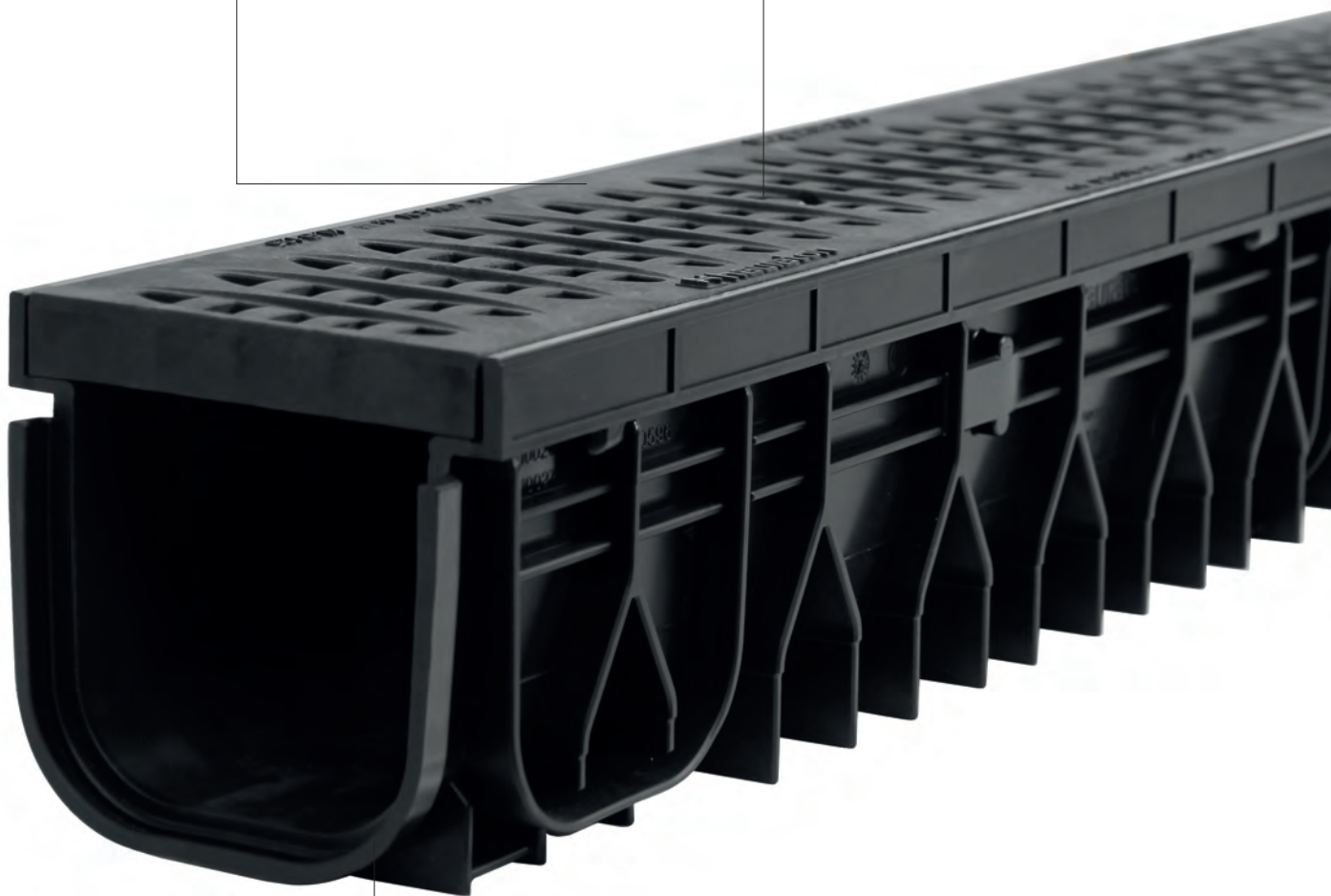

Easy connection

- Interlocking tongue and groove connection allows for a secure and tight connection between adjacent channels

Where is suitable to install DRIVETEC?

DRIVETEC is suitable for lightly trafficked areas with a load class up to B125, such as residential properties, parks and public spaces.

Residential areas

DRIVETEC is a reliable solution for residential areas, particularly driveways and car ports because it offers efficient drainage that helps to keep homes safe and free from flooding.

Quick to install, homeowners can expect minimal disruption from the off-set, with very low maintenance going forward.

Parks

DRIVETEC is ideal for parks due to its heel-safe grating, designed to prevent trips and falls by keeping heels and small objects from getting caught.

Its strong, long-lasting materials make it reliable and durable in all weather conditions.

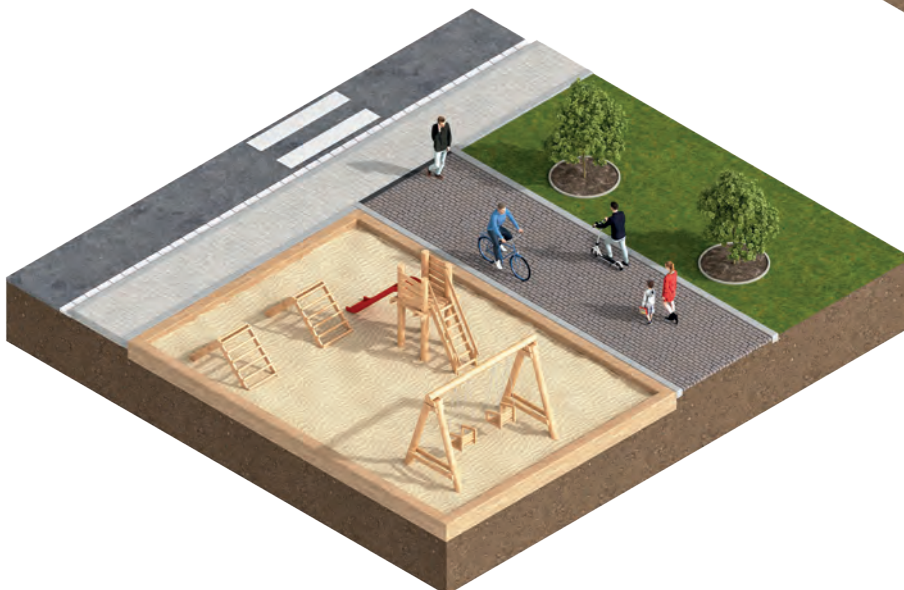

Public spaces

DRIVETEC is an excellent choice for public spaces, combining innovative design with practical functionality.

Its modern appearance seamlessly integrates with various landscapes, enhancing the visual appearance.

DRIVETEC effectively prevents flooding, ensuring these areas remain safe and accessible even during heavy rainfall.



New build developments

Installing HAURATON DRIVETEC in new build developments offers numerous advantages for developers. Made with recycled materials, DRIVETEC supports sustainable construction practices while providing efficient surface water management to prevent pooling and flooding.

Its design ensures easy installation, making it cost-effective and ideal for large projects. The system is known for safety, reliability, low maintenance and longevity, ensuring a durable and attractive exterior to properties that meets the high standards expected in new developments.

Sustainable choice

Environmental benefits of recycled material



Reusing and recycling materials diverts waste from landfill.

With the growing concerns over climate change, it is imperative to adopt solutions that mitigate environmental impacts. Since the construction industry is one of the largest consumers of natural resources, it is now more important than ever to prioritise sustainable material choices.

HAURATON's DRIVETEC channel body is manufactured using recycled polypropylene (PP) material instead of virgin materials. This is a conscious decision that we have taken to reduce environmental degradation and resource depletion.

Recycled materials, such as post-consumer plastic, help to cut down the need for raw materials, preserving natural resources and reducing carbon emissions.

Utilising post-consumer waste instead of virgin materials also curtails landfill usage and lessens overall environmental impact.

272 tonnes of post-consumer waste are diverted from landfill and used to produce HAURATON channels annually*

Beyond material choices, HAURATON implements several sustainable initiatives across their supply chain.

Our factory is equipped with almost 3000 photovoltaic panels generating over 2000kWh per day.

Over 90% of the energy used for production and factory operations is from a renewable source.

By incorporating recycled materials into HAURATON channels, **over 80% of CO2 is saved** per tonne of granulate used.

*According to latest records in 2022.

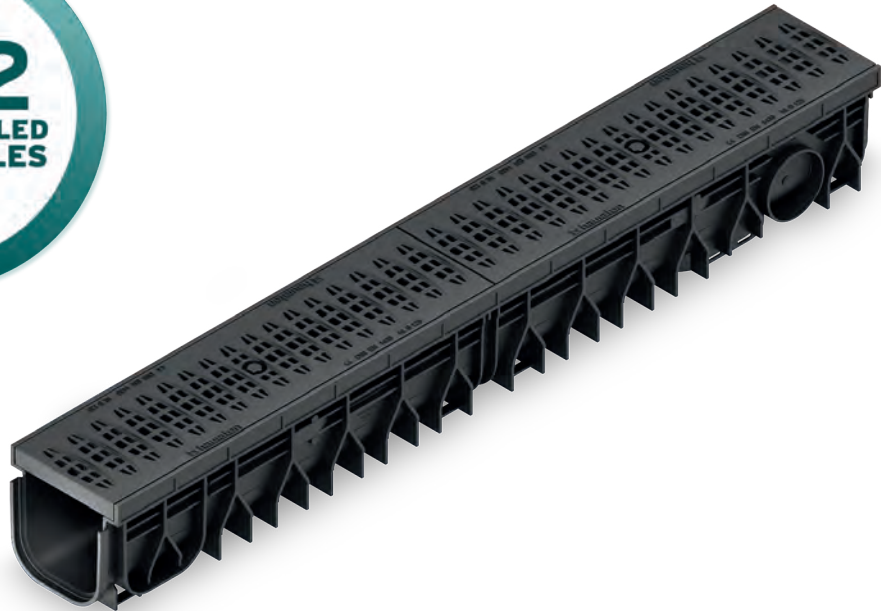

DRIVETEC composite channels are strong and robust.

Furthermore, HAURATON quantifies the use of recycled materials effectively. Each metre of DRIVETEC channel equates to **42 recycled PP bottles**.

This tangible measurement highlights our ongoing contribution to recycling efforts and resource conservation.

Quantifying the use of recycled bottles allows you to visualise the recycled waste across an entire project.

For example, a large scale installation using hundreds of metres would equate to the recycling of thousands of bottles, vividly demonstrating the project's impact.

DRIVETEC is an ideal solution for projects aiming to achieve a carbon reduction or Net Zero status.

Recycled polypropylene is a resilient material, offering strength and durability.

The DRIVETEC channel body is made from recycled material, equivalent of 42 recycled plastic bottles*

DRIVETEC is designed for effective hydraulic performance. The carefully considered materials offer longevity with low maintenance.

To learn more about our sustainable initiatives, manufacturing processes, materials and environmental impacts, please visit our sustainability web page.

***Weight equivalent of 0.5 litre polypropylene bottles.**



Find out more: www.hauraton.com/sustainability

Installation of DRIVETEC

DRIVETEC can easily be installed into a variety of materials. Here are the key steps for an asphalt installation.

1

Excavate trench

Set out / mark out location of channel and determine where the drainage connection will be.

Dig out the trench for DRIVETEC to the correct depth to allow for the required bedding layer.



2

Place bedding concrete and align channels

Place bedding concrete into the trench and set channels onto the bed using a line or level.

Connect drainage pipe or trash box.





3

Concrete surround

Pour / place the concrete surround.

Finish concrete to allow for final finish.

4

Complete installation

Install final surface finish.
Flush system.

Check all bolts for tightness.



Case study

DRIVETEC can be seamlessly installed in block paving, making it an ideal solution for residential properties. Serving as an efficient surface water management system, it effectively handles runoff around the front of houses and garages.

In the example below, DRIVETEC effectively handles surface water runoff in front of a garage door.



- Corners can also be mitred at a 90 degree angle if needed.

Specifically designed to enhance the aesthetics of driveways and landscaped areas, DRIVETEC integrates with various paving styles.

The contemporary pattern adds visual appeal to properties, ensuring that outdoor spaces are both practical and design focussed.



- Channel gratings are bolted to the channel base for added security.

DRIVETEC components

Discover the DRIVETEC system

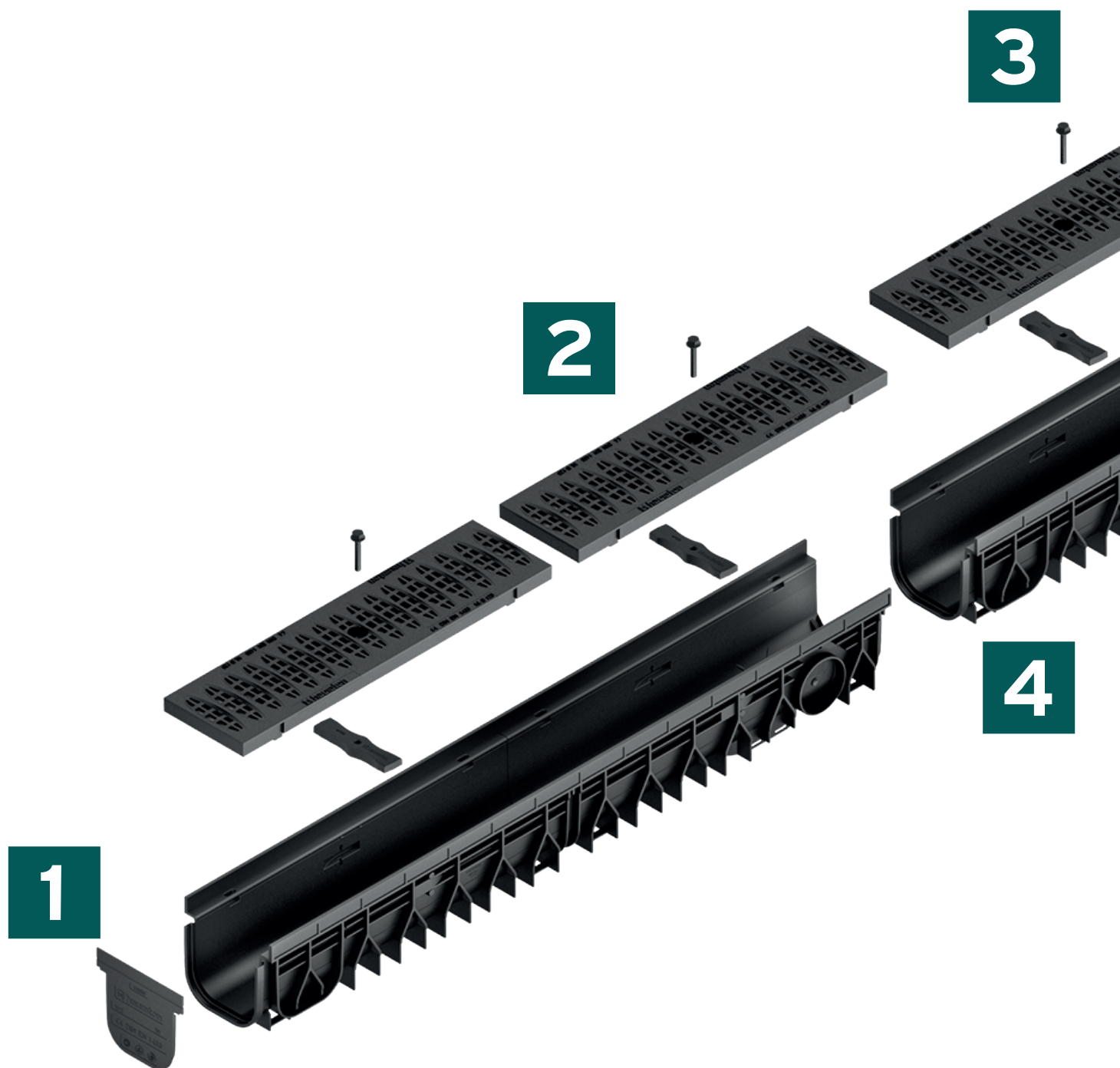

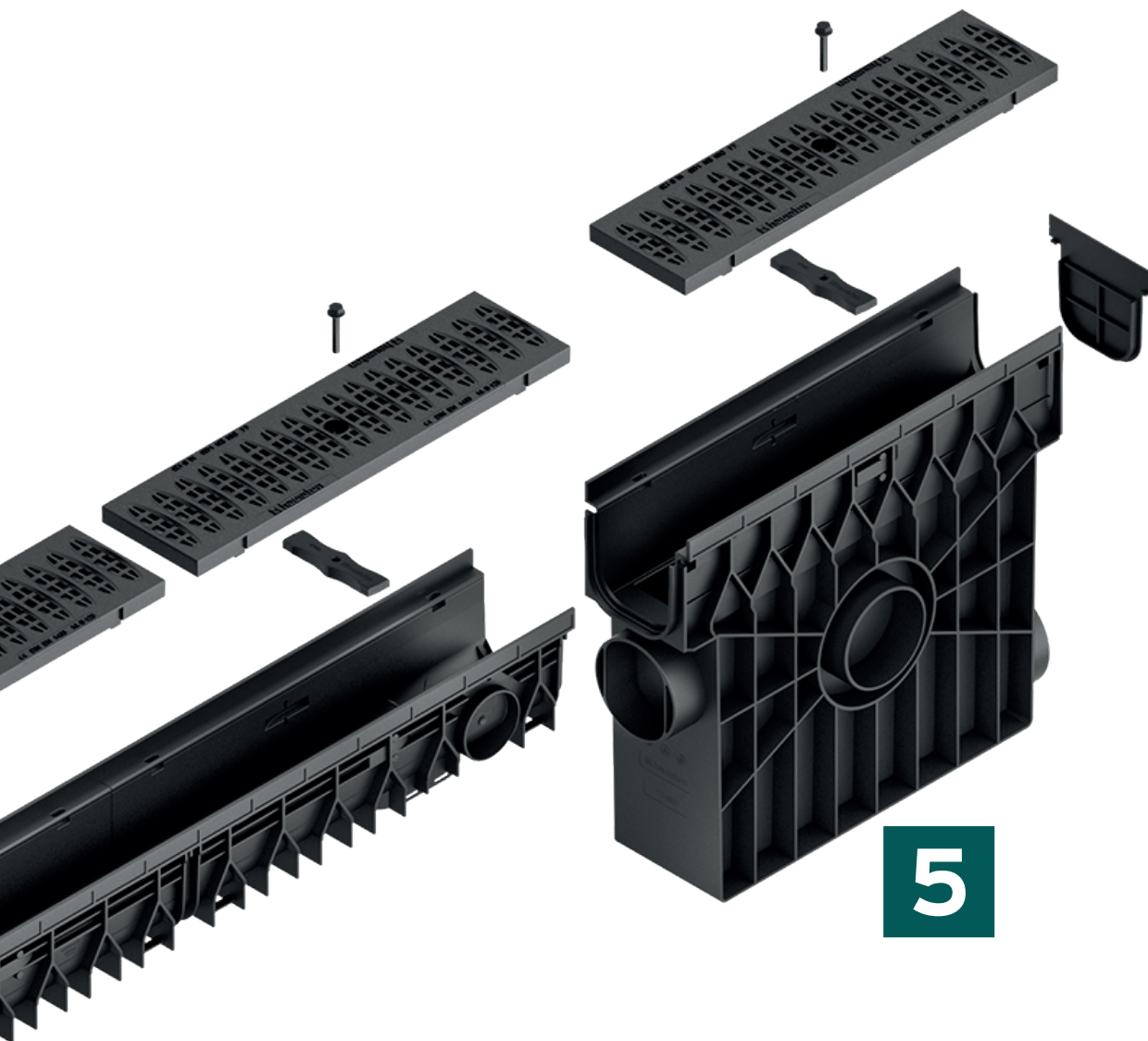

- 1** End caps available for DRIVETEC PA and DRIVETEC ST
- 2** Gratings: composite, heel-safe composite and heel-safe ductile iron
- 3** Bolts for fastening grating to the channel base
- 4** Interlocking connection to secure channels together
- 5** Trash boxes supplied with grating to match remainder of the channel run

DRIVETEC PA 100

Channels

DRIVETEC PA 100, CLASS B125 with composite slotted mesh grating heel safe

Type 01, 1,0 m

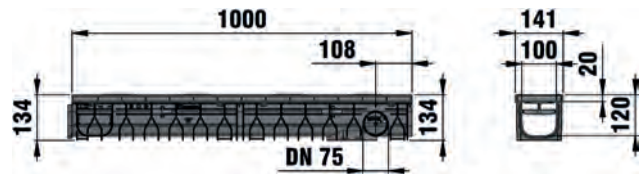

	Length mm	Width mm	Height mm	Internal channel cross-sect. cm ²	Weight kg	Item No.
Type 01, 1,0 m	1000	141	134	95	3.67	10659

DRIVETEC PA 100, CLASS B125 with composite mesh grating

Type 01, 1,0 m

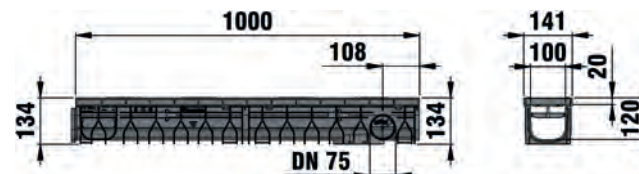
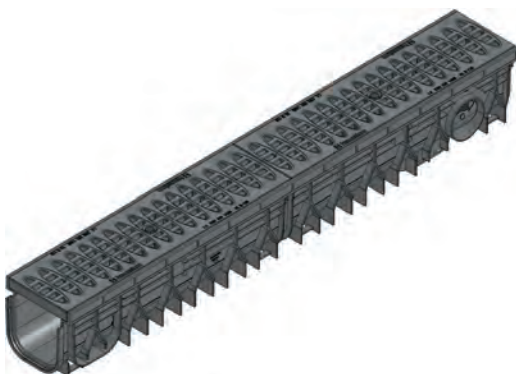

	Length mm	Width mm	Height mm	Internal channel cross-sect. cm ²	Weight kg	Item No.
Type 01, 1,0 m	1000	141	134	95	3.26	10237

DRIVETEC ST 100

DRIVETEC ST 100, CLASS B125 with ductile iron grating heel safe

Type 01, 1,0 m

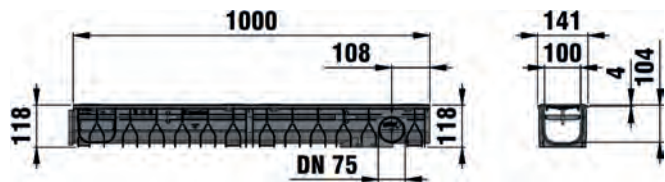
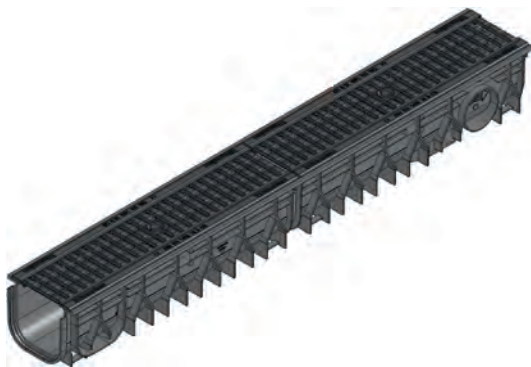

	Length mm	Width mm	Height mm	Internal channel cross-sect. cm ²	Weight kg	Item No.
Type 01, 1,0 m	1000	141	118	95	7.75	10661

Accessories



PA/ST Pipe Connector DRIVETEC PA 100 End Cap DRIVETEC ST 100 End Cap DRIVETEC PA Trash Box DRIVETEC ST Trash Box

	Length mm	Width mm	Height mm	Thick- ness mm	Item No.
DRIVETEC PA and ST 110 pipe connector	141	97	92	-	10056
DRIVETEC PA 100 Type 01 end cap	-	139	124	3	10050
DRIVETEC ST 100 Type 01 end cap	-	139	108	3	10051
DRIVETEC PA 100 trash box composite slotted mesh	500	141	440	-	10655
DRIVETEC PA 100 trash box composite slotted mesh heel safe	500	141	440	-	10656
DRIVETEC ST 100 trash box ductile iron heel safe	500	141	424	-	10653



HAURATON UK

Unit 4, French's Avenue
Dunstable
Bedfordshire
LU6 1BH
Tel. 01582 501380
sales-uk@hauraton.com